

## Unmanned Navigation and user Interface for Aerial Vehicles

*Petrou f. Palogos A. Kavoussanos E. Palamas G. Papadourakis G.*

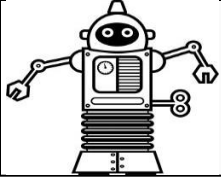

**Technological Educational Institute Of Crete  
Department Of Applied Informatics and Multimedia**



# Automation and Robotics Laboratory

**Autonomous air vehicle combines sensed heading and spatial coordinates and a user defined mission statement.**

**Modulated data produce navigation reference signals used to autonomously control the plane.**

**The system can switch, through remote control, between automatic or manual operating modes while in flight.**

**Additionally, a highly interactive user interface control serves for both trajectory editing and programming and flying data acquisition.**

**Experimental data shows that the plane is able to navigate between predefined coordinates and reach target positions.**

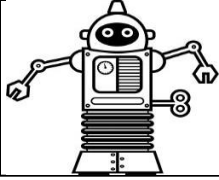

## UAV Design Requirements

- Use and development of UAV for military and civilian applications is rapidly increasing.
- Similar to the manned aircraft the challenge is to develop optimal configurations to produce a high performance aircraft that satisfy the mission requirements.
- UAV systems are ever increasingly becoming important topics for aerospace research and industrial institutions.
  - Difficulties in these new concepts are
    - the compromising nature of the missions to be performed, like high or medium altitude surveillance
    - variable environments and many others.

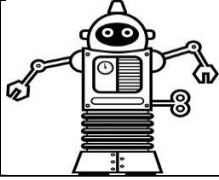

## How UAVs Operate

Unmanned Aerial Vehicle, also known as a drone,  
an aircraft without a human operator on board

UAVs are flown and navigated by onboard computers  
and operated by humans on the ground

Software code containing the entire mission plan is downloaded  
to the UAV's computers before or after it is launched

The operator on the ground does not "fly" the UAV  
but can change the mission plan by sending new software  
instructions to the computers via radio

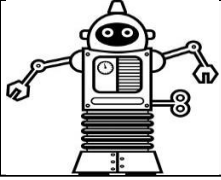

# Automation and Robotics Laboratory

## General Schematic

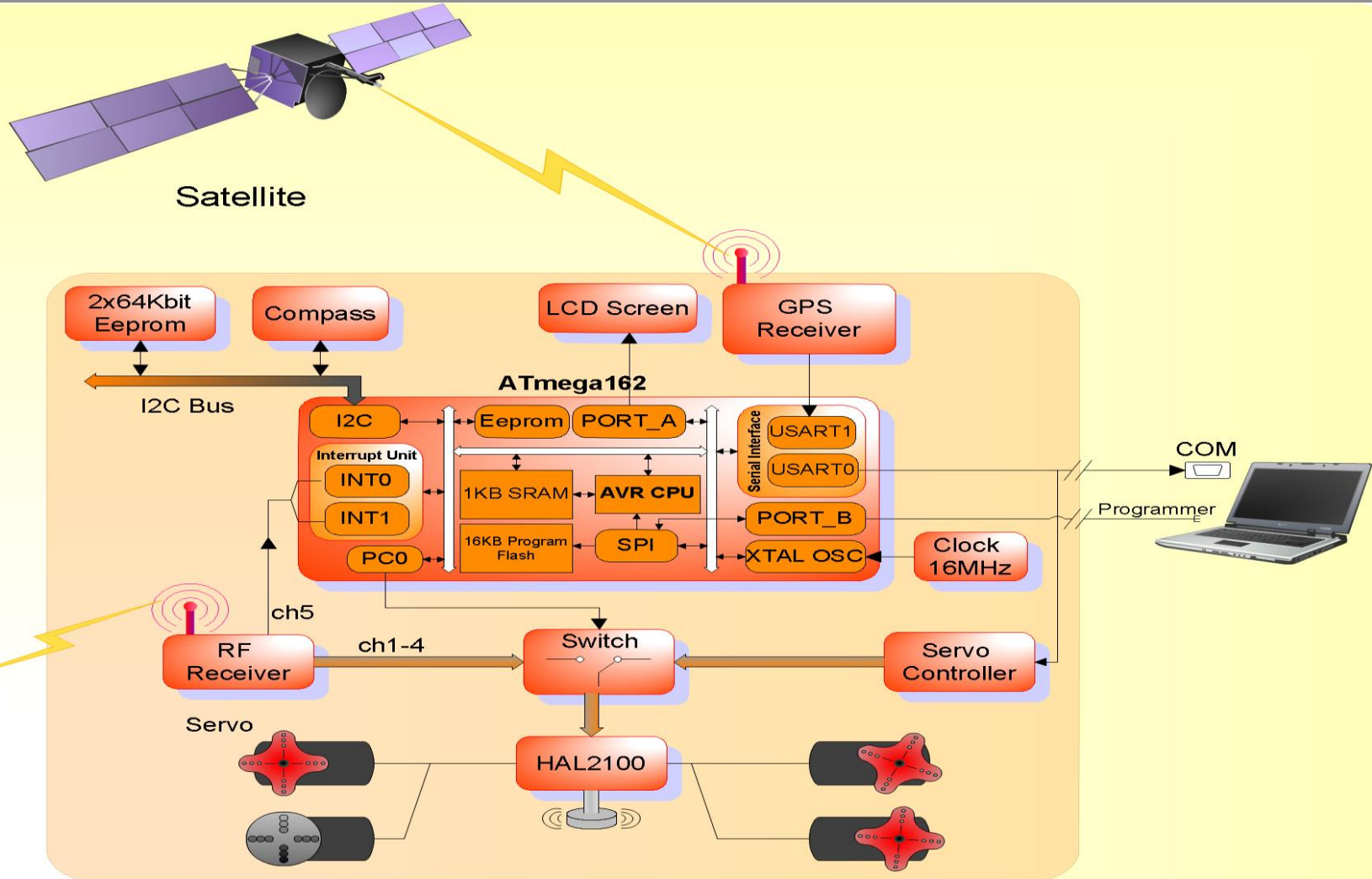

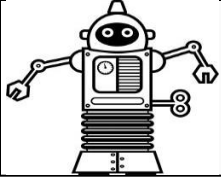

## Control Board

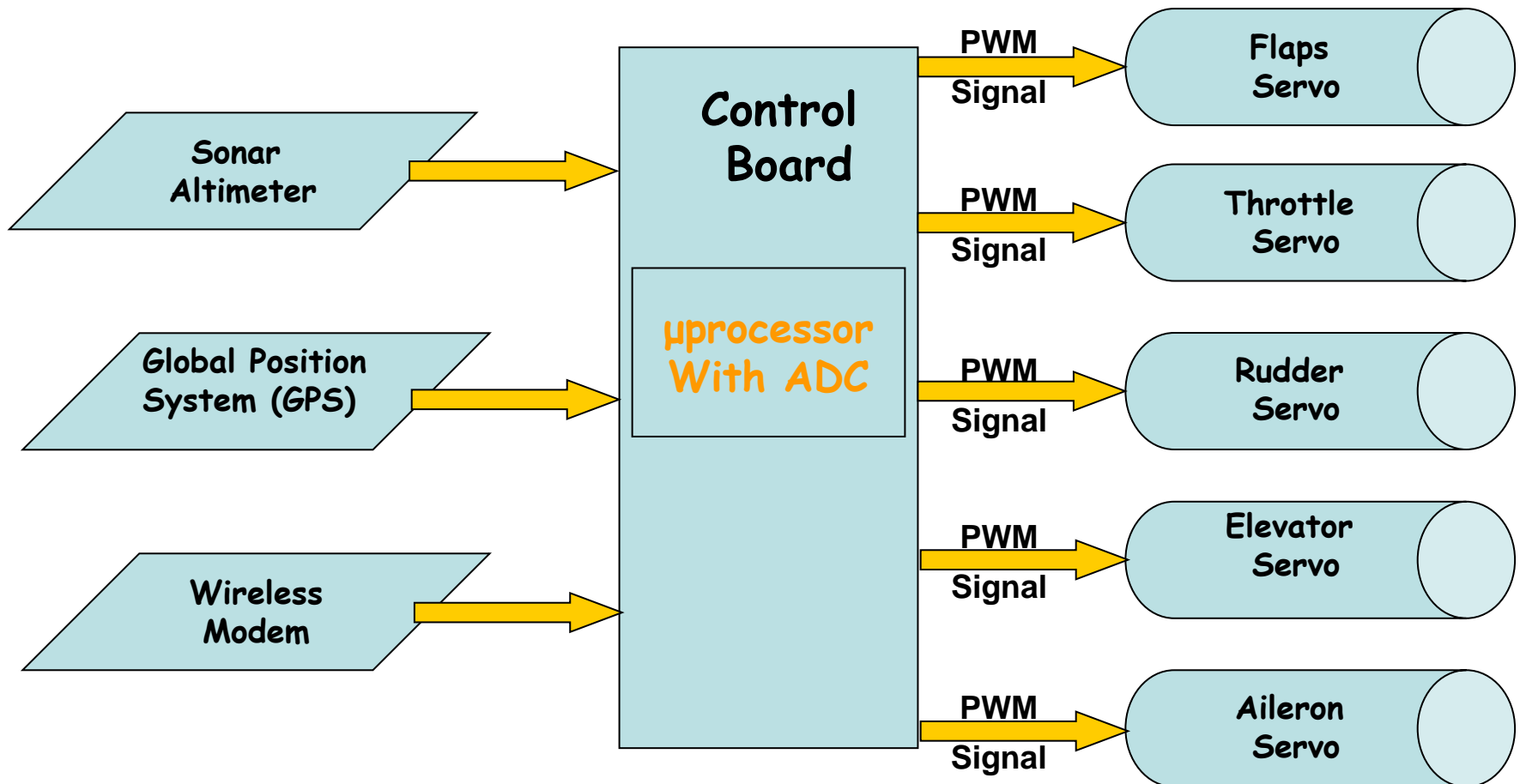

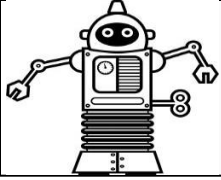

## Operational Modes

- ❑ Autonomous with the aid of autopilot
- ❑ Guided from the user (take off, landing, general emergency case)

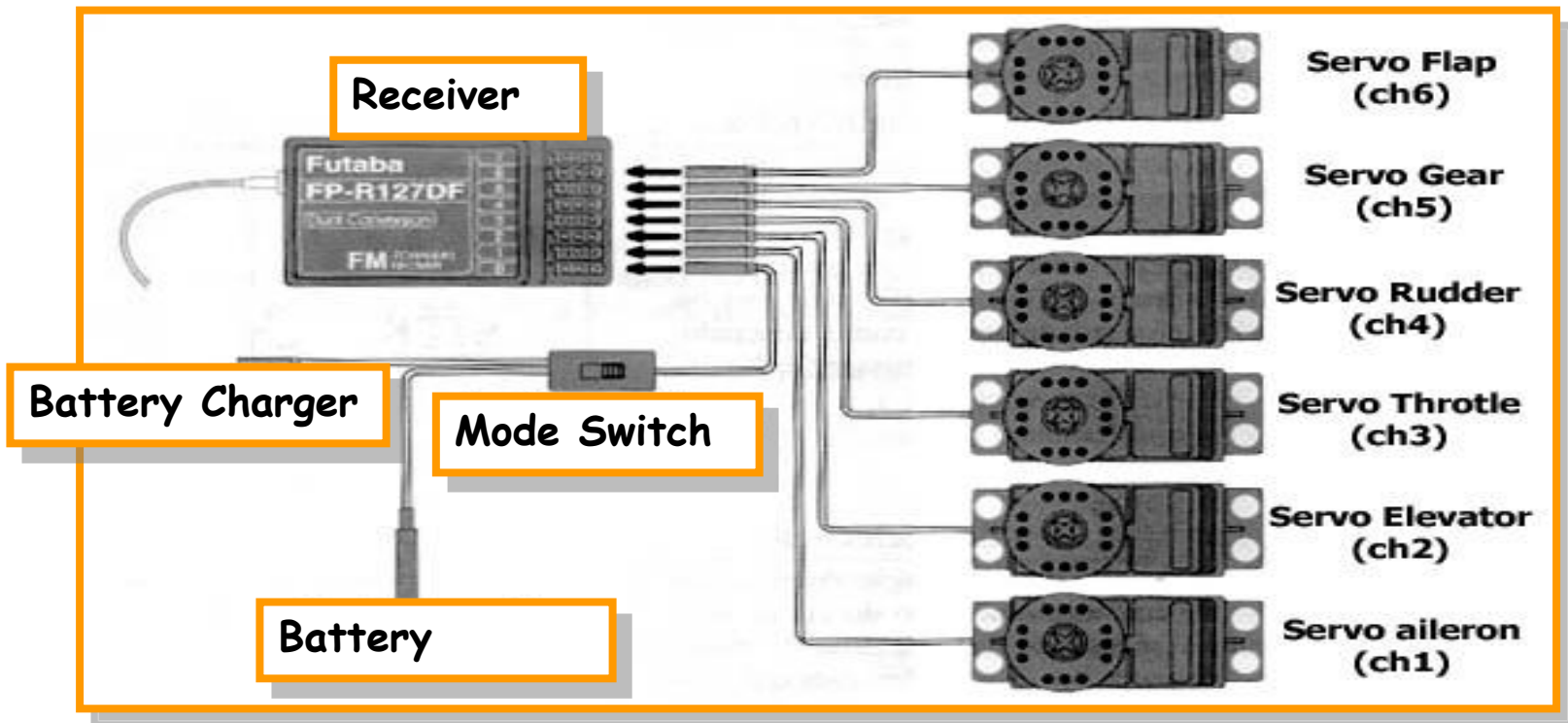

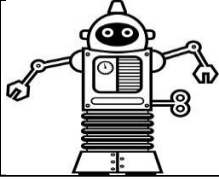

## I2C Protocol

- I2C is a 2-wire, half-duplex, serial bus
- multi-master serial computer bus invented by Philips
- used to attach low-speed peripherals to embedded systems
  - ❑ Compass
  - ❑ Global Position System receiver
  - ❑ Altitude sensor
  - ❑ Gyroscope

Figure 1: I2C 2-wire Interface

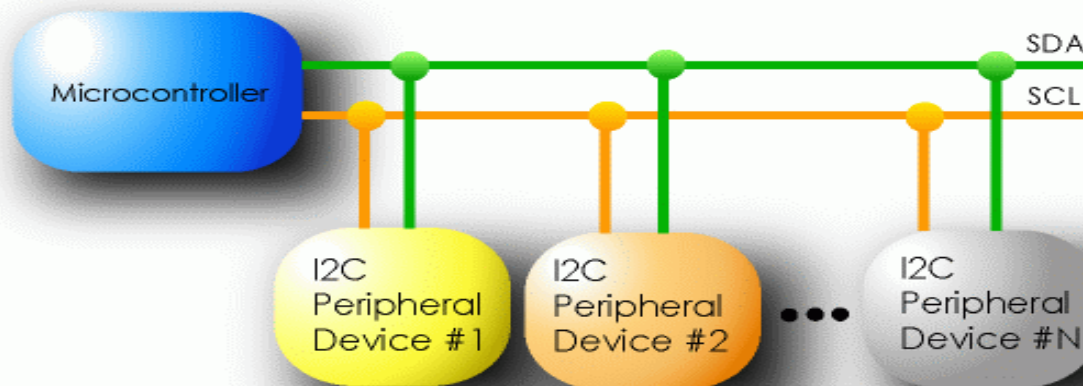



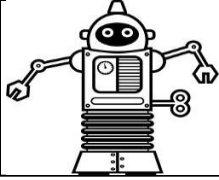

## Autopilot HAL 2100

- Horizontal Auto Levelling system
- Safely manoeuvres plane
- optical sensor monitors the attitude 100 times every second
- Integrated microprocessor instructs the servos to return the aircraft to straight and level flight

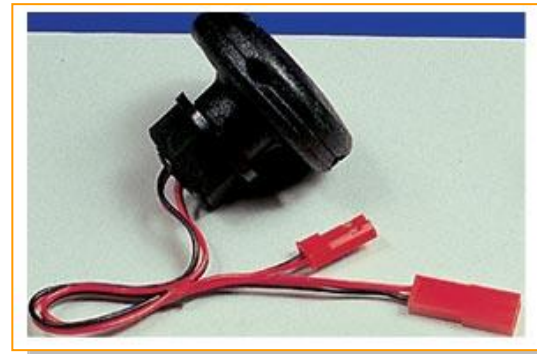

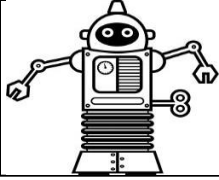

## What is a Kalman filter (1/2)

The Kalman filter is an efficient recursive filter that estimates the state of a dynamic system from a series of incomplete and noisy measurements.

Information regarding location, speed, and acceleration of the plane is measured with a great deal of corruption by noise at any time instant.

Kalman filter exploits the dynamics of the target, which govern its time evolution, to remove the effects of the noise and get a good estimate of the location of the target at:

- present time (filtering)*
- at a future time (prediction)*
- at a time in the past (interpolation or smoothing).*

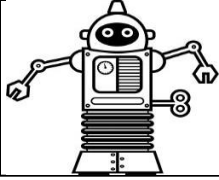

## What is a Kalman filter (2/2)

- ❑ Optimal recursive data processing algorithm
- ❑ Typical Kalman filter application:

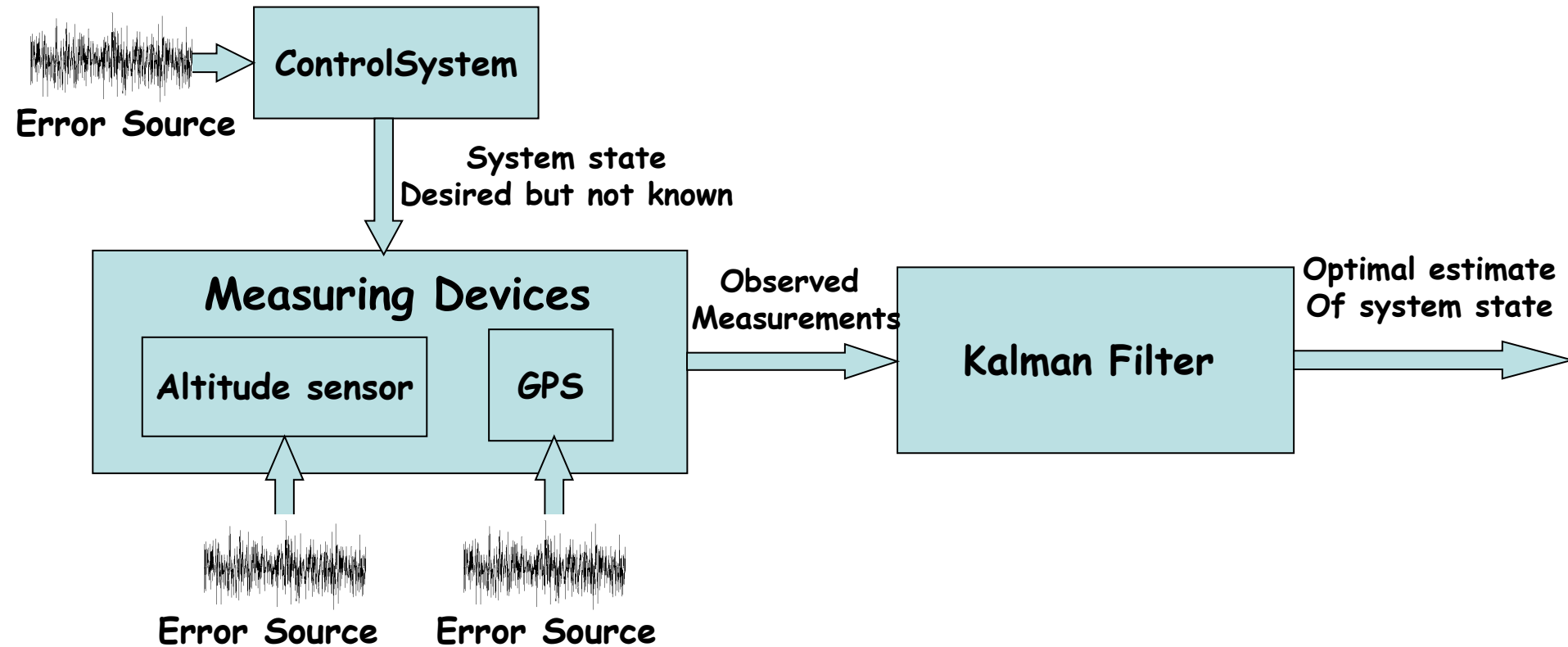

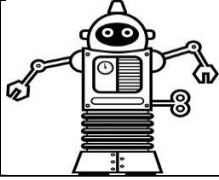

## Least Squares Method

least squares is a method for linear regression that determines the values of unknown quantities in a statistical model by minimizing the sum of the residuals (the difference between the predicted and observed values) squared.

The least-squares approach to regression analysis has been shown to be optimal in the sense that it satisfies the Gauss-Markov theorem.

- ❑ The objective consists of adjusting a model function to best fit a data set.
- ❑ The chosen model function has adjustable parameters

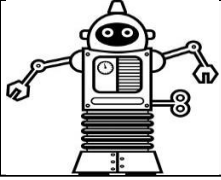

## Least squares trajectory planning

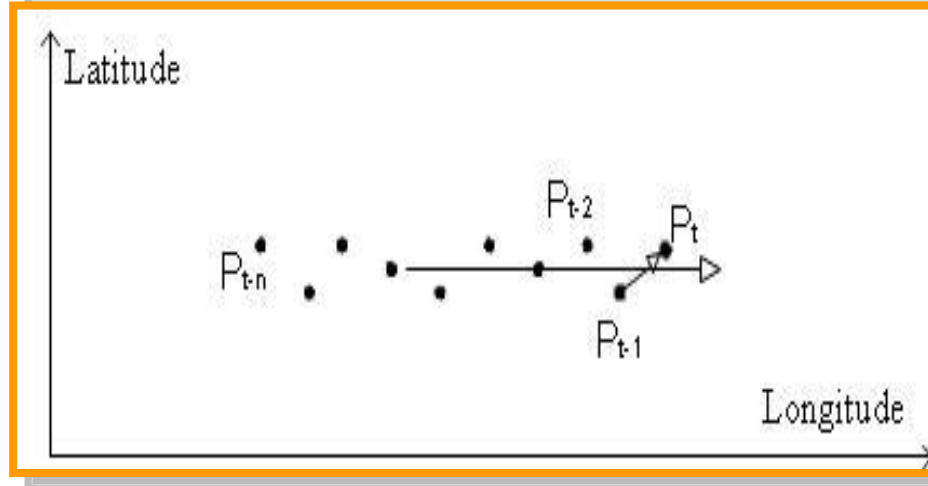
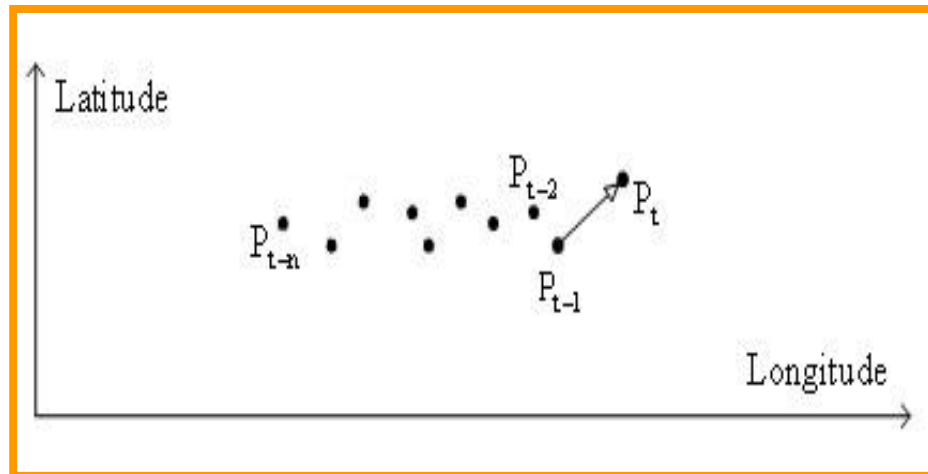

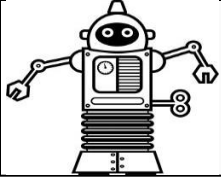

## Optimal Route planning

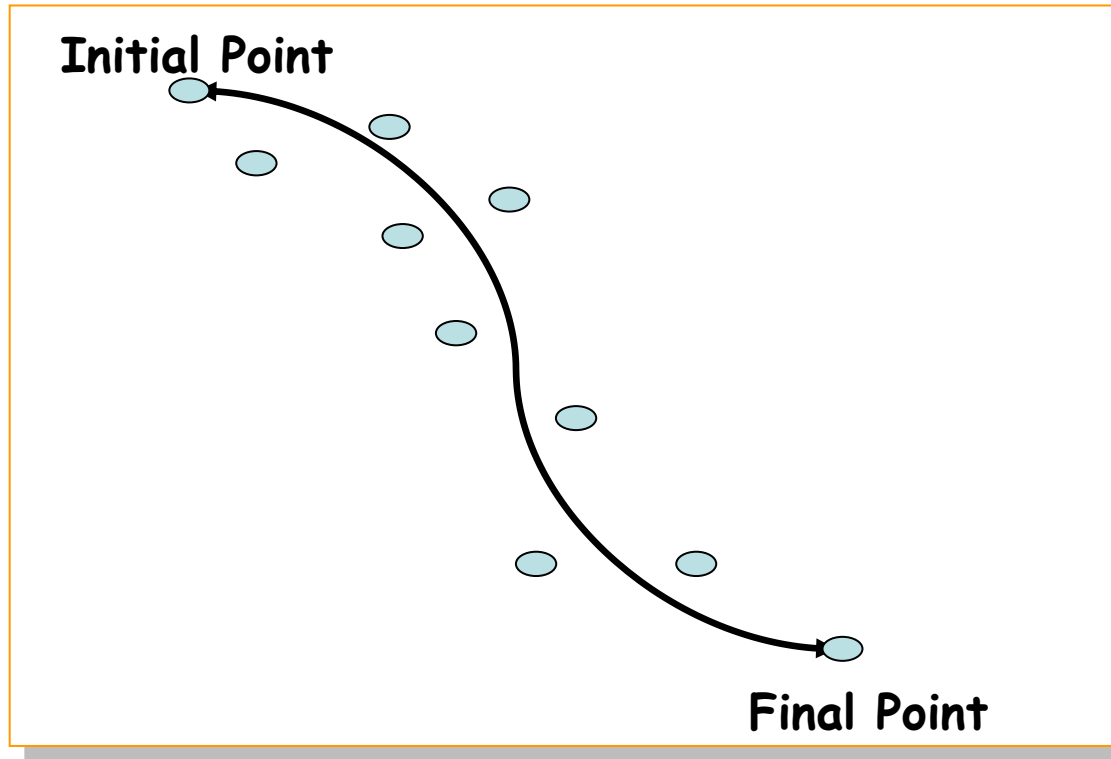

- ❑ Find minimum distance route
- ❑ Efficiently control speed and acceleration

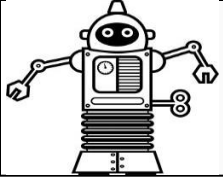

## Different Routes for Different Parameters

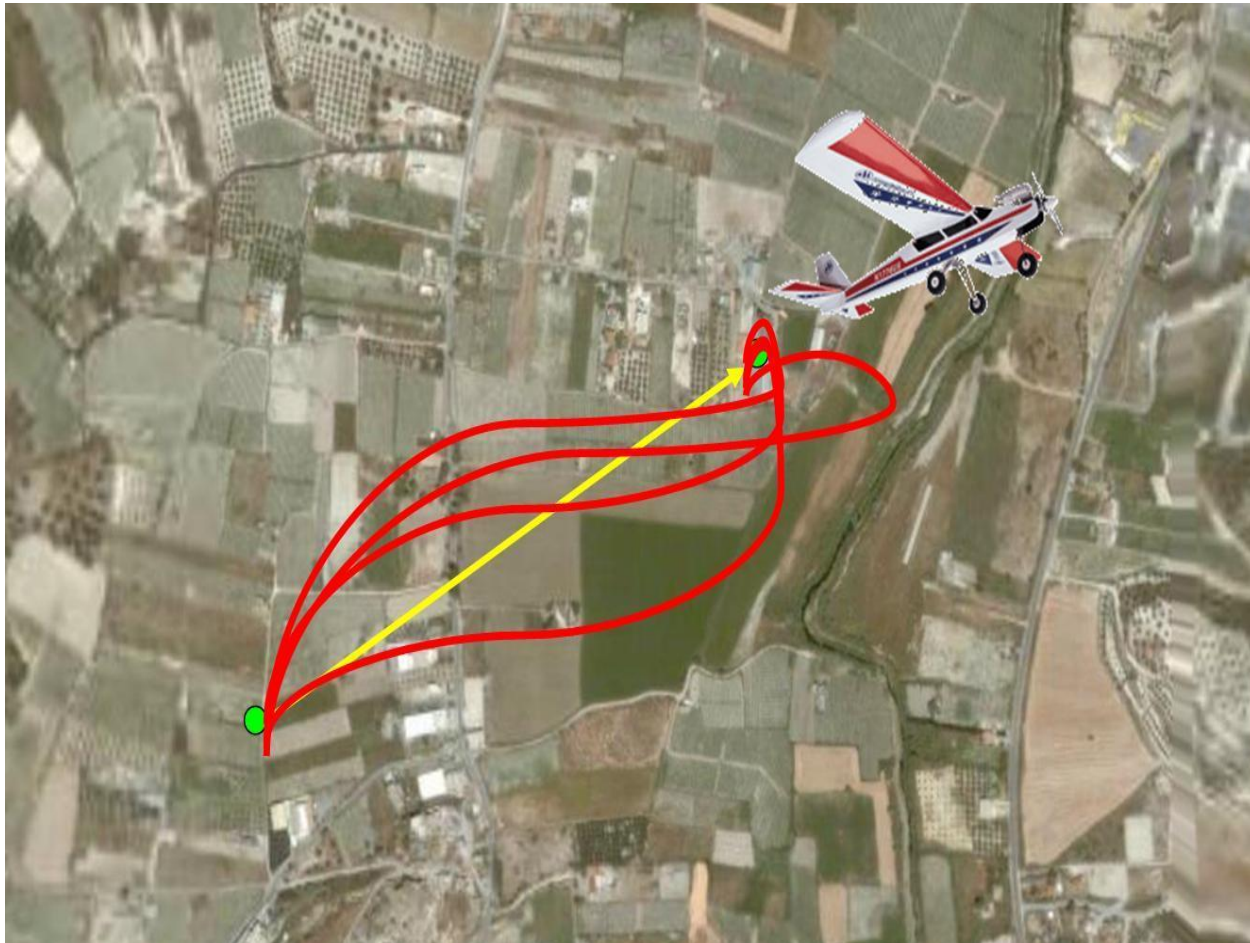

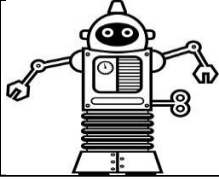

## Monitoring and Control Software

Software interface for "Faethwn Project v beta 1".

Design your Route (5 points):

Map Calibration

25.10055	25.10340
35.31637	
	Longitude
	Latitude
35.31444	

pixels Lon/Lat

313,485	(1): 25.10167 35.31481
331,124	(2): 25.10173 35.31597
287,86	(3): 25.10157 35.31609
253,453	(4): 25.10145 35.31491
273,501	(5): 25.10152 35.31476

Calculate your route:

Estimated Possible Speed:  Km/h

Send/Receive

<input type="button" value="Send"/>	Send Coordinates data to Phaethwn
<input type="button" value="Receive"/>	Receive coordinates data from Phaethwn's EEPROM
<input type="button" value="Com Port"/>	Setup Com Port

Total: 271.85 m

Image © 2006 DigitalGlobe  
© 2006 Europa Technologies

lon 25.10106 lat 35.31636 (143.4)



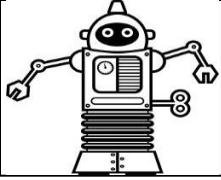

## Conclusions

- ❑ Model Plane is able to navigate through predefined positions
- ❑ Predictable behaviour for stable conditions like wind speed

### *But*

- ❑ Parameters can only be adjusted through trial and error
- ❑ Different conditions like wind speed means different behaviour
- ❑ Microcontrollers are not very well suited for computations like Kalman filters and Least Squares

